

Simple Class A Amplifier

A postscript to the design published last year

by J. L. Linsley Hood

The author has had the benefit of an extensive and frequently helpful correspondence with readers following the publication of the circuit design. Attention has been drawn to some obscurities in the original article and to certain possible improvements in the design. Details are given below.

Power supply

Although much interest was aroused among constructors by the good technical (and audible) performance given by the amplifier, it is clear that the principal feature in the eyes of many users was the relative simplicity of the circuit. This being so it must have seemed a pity that the power-supply unit was somewhat complex. However, the purpose of this power-supply design was to avoid possible degradation of the amplifier performance by h.t. ripple. The sawtooth ripple voltage across the reservoir capacitor in a class-A amplifier drawing some 2-3A will be many times greater than in a class-B system, particularly at the audibly important low-signal levels.

However, a number of measurements have been made since the publication of the original article on an amplifier of this type, operated from a simple supply unit of the type shown in Fig. 1. There is little difference in the performance above 100Hz either in total harmonic distortion or in intermodulation distortion, although the shape of the output power/distortion curve at the onset of overload is modified, as would be expected, by the ripple on the h.t. line. Below 100Hz the distortion curve rises more steeply to about 0.2% at 20Hz.

A thermister is necessary, in this case, to slow down the rate of rise of the h.t. voltage. This will get hot in use.

It now appears that the mains transformers used in the development of the prototype of this amplifier were not as efficient in respect of apparent secondary circuit resistance or secondary leakage reactance as some of those which have been supplied for this purpose since the publication of the article. The reservoir voltage found with the 15Ω system may be above that given by the author. At switch-on this can cause a transient overloading of the transistors specified for the series regulator circuit in the original article. In view of this, it is suggested that these should be an MJ481 or 2N3055, used in conjunction with a 2N1613 or, better still, a 2N699. These amendments are shown in Fig. 2.

Adjustment of amplifier output current and centre-line potential

The author had supposed, somewhat naively, that most constructors of the circuit would have somewhere in their workshops a collection of odd-value resistors needed for trimming circuit parameters, and it was mentioned in the original article that the desired quiescent levels could be set by adjustment to R2 and R5 or R6. This sort of comment is unhelpful if one is writing away for a kit of parts. In view of this it is suggested that R2 should be replaced by a resistor in series with a potentiometer, as shown in Fig.1. The necessary value of resistors R5 and R6 to give an entirely adequate accuracy in the mid-point voltage setting can be predicted, and the suggested amended values are shown.

Some obscurity arose, inadvertently, in the original diagram concerning the reason for the different values of input decoupling resistor quoted for mono and stereo use. This was because it was intended that the one decoupling circuit should serve both channels. Where an unsmoothed h.t. supply is used it is recommended that the decoupling capacitor should be increased in value to 250μF.

Stability of output current setting

Some criticism has been voiced because there is no specific control over the output current value in the simplest form of this circuit, other than that due to the stability of the current gain of Tr2, whose performance determines this parameter. In order to meet this point (in anticipation) a circuit was described in the original article which allowed precise control over the operating 'quiescent' current without detriment to the performance of the amplifier.

However, measurements made on an amplifier without this addition have shown no significant change in operating current in somewhat over two years use, and there is also little measurable difference in current from a minute or so after switch-on to the end of a six-hour period of continuous use. In practice therefore, in temperate climates at least, the simplest form of the circuit is adequate in this respect. If any user cares to experiment with an alternative and somewhat more elegant form of quiescent-current control another regulation circuit is shown in Fig. 3. The transistor used as Tr5 requires to be somewhat more massive than that used for Tr3 since the mean collector current is twice that of Tr3 and the maximum voltage and current occur simultaneously. The 2N2905A is just about adequate with a good heatsink, but a larger power device such as the 2N4919 is preferable.

Alternative transistor types

The amplifier has been built successfully with a wide variety of transistors, including fully complementary versions to operate from an existing negative h.t. line, and in one case two identical amplifiers have been made for use with the inputs in paraphase, in order to double the available output voltage swing. One constructor has, indeed, made a stereo 30W system using two such pairs of amplifiers plus input phase splitter, as shown in Fig. 4.

However, one transistor change which is recommended is the use of a 2N1711 as Tr3. This has a high voltage capability equal to that of the 2N1613, and a current gain which is double that of either the 2N1613 or the 2N697. The use of the 2N1711 instead of the former types suggested for Tr3 increases the feedback factor and approximately halves the typical distortion factor of the system (0.025% at 9W or 0.05% at full power) without detriment in other respects.

Also, a 2N1711 as Tr3 allows the use of 2N3055 devices as Tr1 and Tr2, with a final performance which is equal to that of the original specification below 100kHz. (The typical current gain of the 2N3055s is only half that normally found with the MJ480/1 output transistors, and their use was not originally recommended for this reason.)

Gain/frequency and power/frequency characteristics

These are, in fact, better than the curves published in April 1969. As mentioned in a letter to the editor published in October 1969, the h.f. fall-off shown was mainly due to an error in the measurement instrument. Although the performance at h.f. depends to some extent on the layout employed, the small signal voltage gain, with the component arrangement shown, is flat (within 1dB) to beyond 2MHz. This may be a snag in some cases because even a small feedback capacitance between output and input (as may happen, for example, if the output heatsinks are not earthed) may cause the amplifier to oscillate. A suitable circuit change to reduce the amplifier h.f. response to more normal levels was described in the letter above. This is not an essential modification – the author's own units are still exactly as described in April 1969.

The output power response of the unmodified amplifier is flat within 1dB to 200kHz.

The l.f. response shown in the original gain/frequency and power/frequency graphs was that determined for an earlier prototype of the amplifier. During the development of the circuit the values of some of the capacitors were increased to improve the l.f. performance, and by an oversight the graphs accompanying the article were not amended. In fact the gain and power graphs can be shown as 'flat' from 10Hz-200kHz. In this respect, and that of transient response, the class-A design is probably better than any circuit so far published. The i.m. distortion, at 10W output, (70Hz and 7kHz, 4:1) is less than 0.1%.

Miscellaneous

Surprise – and even alarm – has been caused to some constructors by the fact that the output transistors get hot. However, with adequate heatsinks, which should be black painted, the dissipations in the transistors are only a small fraction of the maker's permitted level, and provided that some care is taken in the layout to make sure that sensitive components, such as electrolytic capacitors, remain cool, no reduction in the working life of such a system, in comparison with an equivalent class-B unit for example, is to be expected.

Some difficulty has apparently been encountered by some constructors because the power supply regulation system is inoperative when the supply is operated without a load. If an equivalent resistive dummy load is connected for bench-testing, all should be found to be well.

Finally, it is prudent to wire a small resistor of about 2kΩ across the loudspeaker terminals to make sure that the output capacitor charges even with the speaker disconnected. Charging of the capacitor by an accidental short-circuit could cause damage. This addition is shown in Fig. 1. No damage is caused by operating the amplifier on an o / c output.

Figures

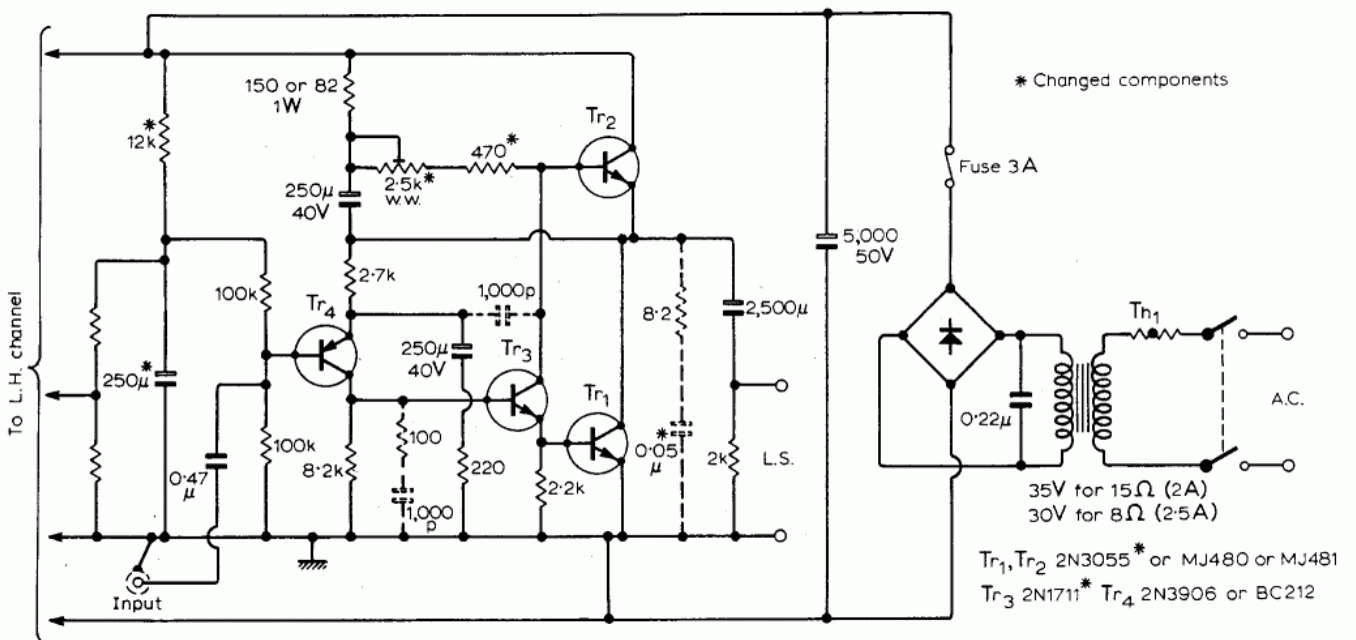

Fig. 1. Suggested amended circuit for 8 or 15Ω use employing a simplified power supply. The dotted components reduce the h.f. response and should be used with capacitive loads.

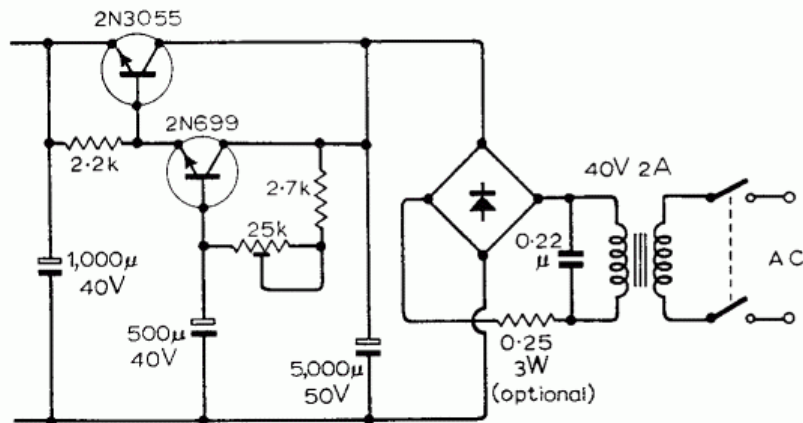

Fig. 2. Amended circuit of power supply for 15Ω systems.

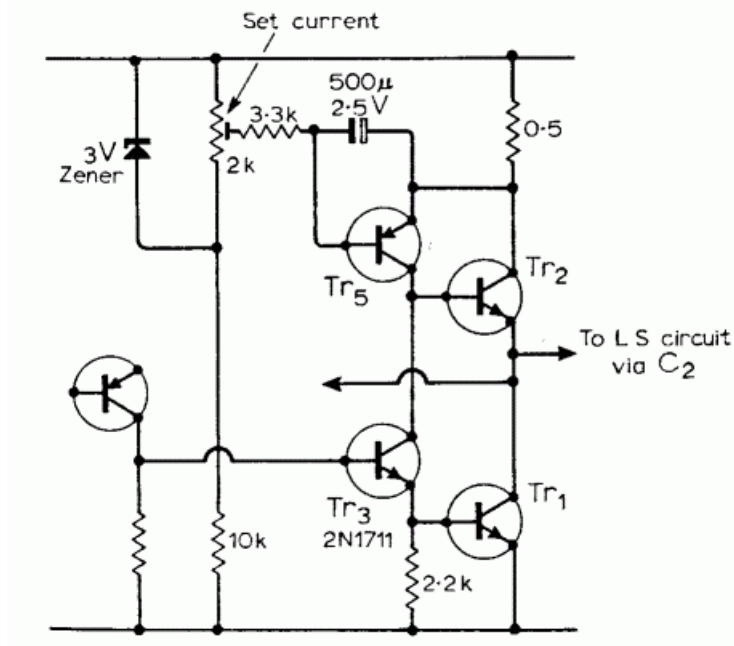

Fig. 3. Alternative method of quiescent-current control. R1, R2 and C1 in the original have been deleted. Tr5 is 2N4919 on heatsink or alternative type.

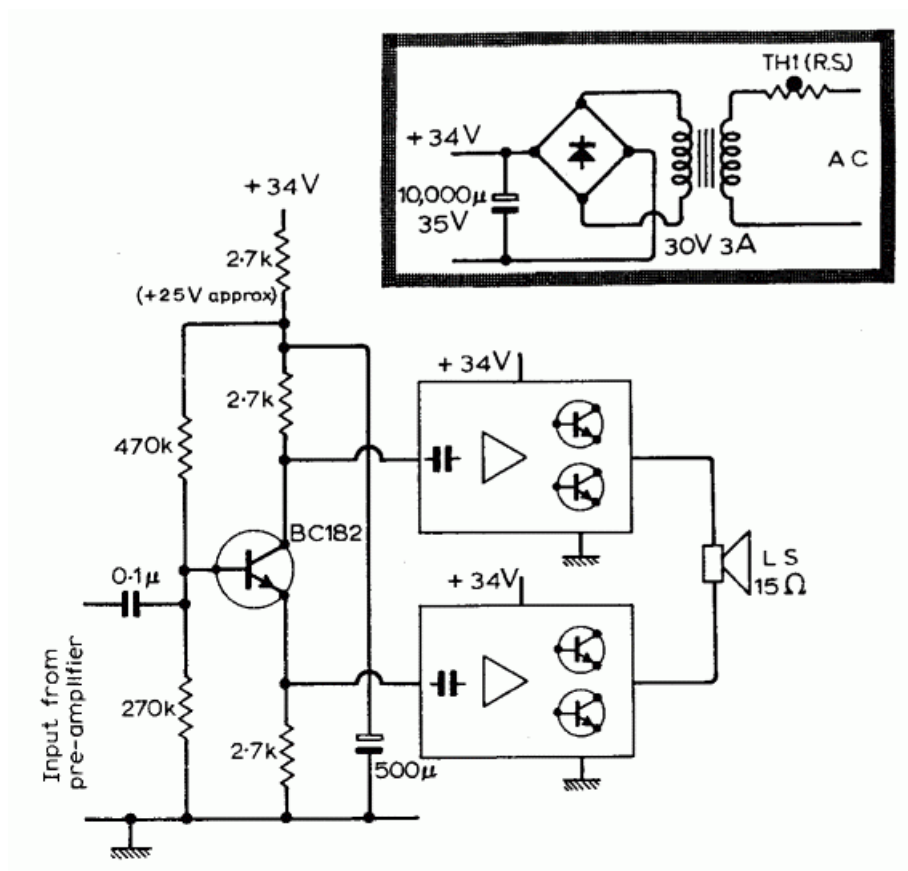

Fig. 4. Scheme for 30W class-A system. The two identical class-A amplifiers, each designed to give 15W into 8Ω (34V at 1.5A), are driven by a phase-splitter. The output capacitors have been removed.